

# AX700

6 Duty / 1 Standby Amplifier Changeover Panel

## AUTO AMPLIFIER CHANGEOVER



AX700 is a platform for standby amplifier to take over failed duty unit in an automated changeover setup. Each unit caters for 6 duty and 1 standby amplifier but expandable to larger setup with a single standby power pack.

It shall be used with amplifiers with auto fault sensing ( AFS ) such as PX series and whereas normal amplifiers are used, Amperes AS4000 shall be installed at every duty unit. In such case, we recommend that Amperes AX3700 to be used instead.

AX700 has protection features that only allow a single takeover to prevent overloading.



### APPLICATION SCHEMATIC

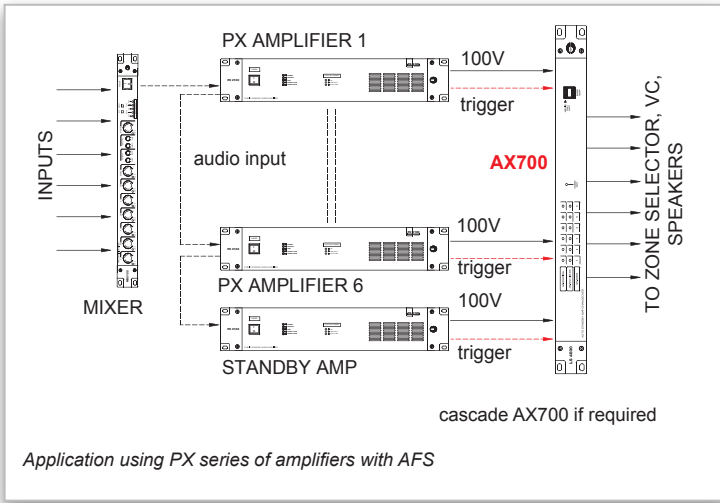
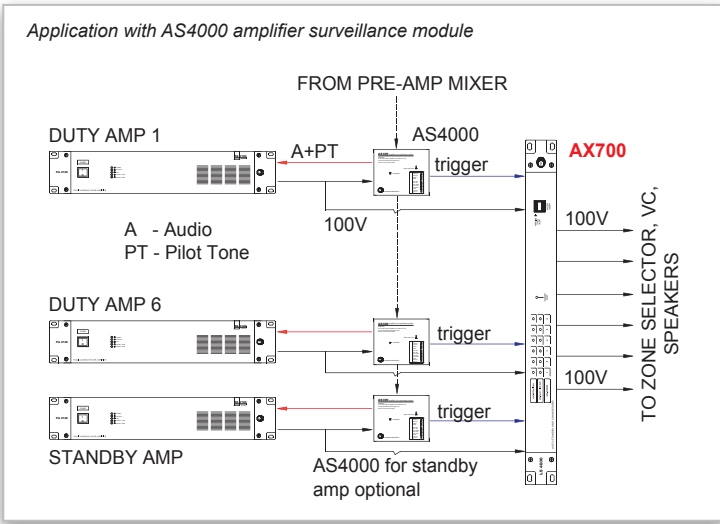

### FEATURES

- Cater for 6 duty and 1 standby amplifier
- Expandable for 1 standby to serve more than 6 duty units
- Overload protection by allowing only a single take over
- Prioritized changeover - unit with higher number is preferred for changeover
- Fault alert with LED indicator and switchable buzzer
- Compatible with most auto detection cards

### TECHNICAL SPECIFICATIONS

Operating voltage	24V DC via PS9400 PSU
Power consumption	Standby : 82 mW, 3.4 A Operating : 1.3 W, 50 mA
Zone load rating	400 W / 100V line per ch.
Amplifier inputs	6 duty / 1 standby
Indications	Red LED for takeover Green - normal / non c/over
Switching mode	Dry contact activation by AS4000 / other contacts
Changeover alert	Buzzer, LED
Changeover section	Amplifier outputs only
Cable connection	Plug in connectors
Cable size	2.5 mm sq
Dimensions (WxHxD)	482 x 44 x 130 mm
Weight	2.0 kg

### packing information

Carton : 555 (W) x 95 (H) x 295 (D) mm  
 Weight : 2.60 kg  
 Qty : 1 units / carton

rear view

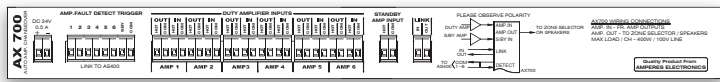

AMPLIFIER CHANGEOVER & MONITORING