



AX3700

Auto Standby Amplifier Fault Changeover

instruction manual



Thank you for choosing another quality product from Amperes Electronics.

Though it is rather simple in the installation works, a brief read through the manual is recommended and we are confident that you are getting a product of excellence.

BY :
AMPERES ELECTRONICS
VER 1 / apr 2007

PARTS IDENTIFICATIONS

FRONT VIEW

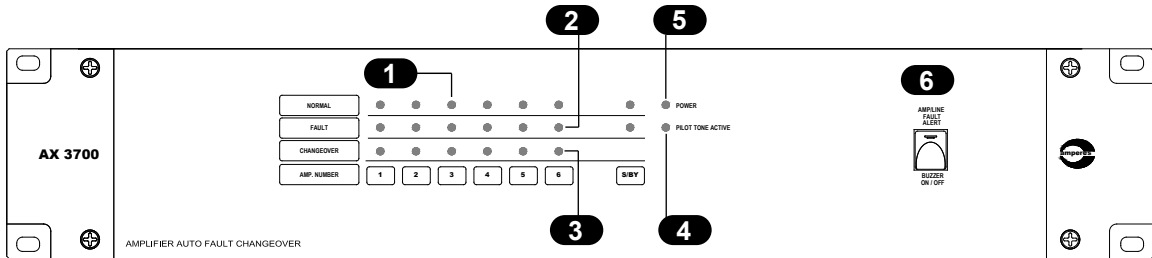

1 NORMAL LEDs

Amplifiers connected to the unit which is operating in good condition shall be represented by the green LEDs. Amplifiers not connected should be switched to disconnect at the rear of the panel to avoid false identification.

2 FAULT LEDs

Amplifiers detected as faulty would be represented by the red LEDs. Fault condition is detected when the Pilot Tone is not detected at the amplifier's 100V line output.

3 CHANGEOVER LEDs

In the event of standby takeover of the faulty duty amplifier, the LED shall lit at the faulty channel. At any one time, only one take over shall take place to prevent overloading.

4 STANDBY AMP FAULT LED

This LED shall lit when the standby amplifier is detected as faulty. When this occurs, a changeover shall not take place whenever any duty unit is found faulty.

5 PILOT TONE ACTIVE

Pilot tone shall be sent at intervals to every channel of amplifier inputs. Whenever this is sent, the LED shall lit.

6 FAULT BUZZER

Whenever a faulty channel is detected, a buzzer shall be activated and the alarm can be switched off while the red LED shall remain on.

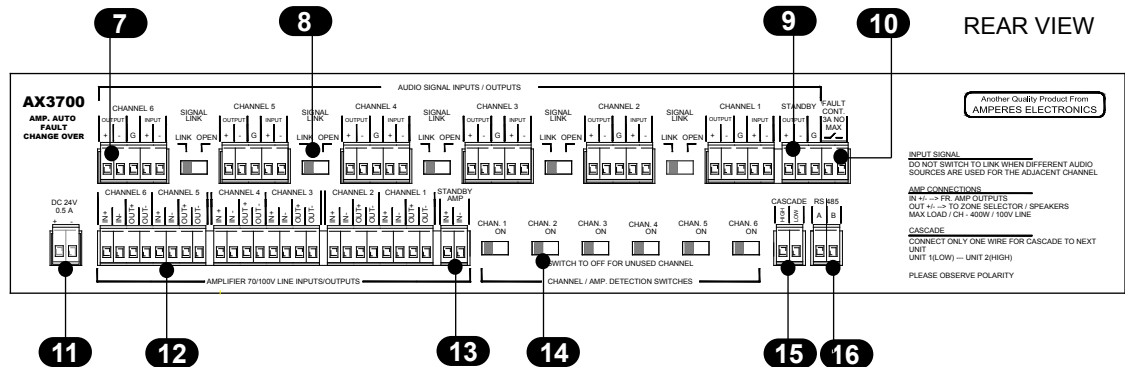

7 AUDIO IN / OUTPUT PORTS

Audio output from pre-amplifier mixer is connected to this port at "Input" terminals before link it to the amplifier audio input via "Output" terminals. Signal ground shall be joint together as they are common. If all amplifiers share a common source, terminate only at channel 1 and utilise the signal link switch to join all the input terminals. Please refer to the chapter "Connecting Input Source".

8 SIGNAL LINK SWITCH

Switching the switch on shall link the input source from one channel to the other. Use this only when two or more amplifiers share common input source. For matrix system, some zones may have different sources, thereby please disable the switch to break the joint to the adjacent channel.

9 STANDBY AMPLIFIER INPUT SOURCE

Connect the input source of standby amplifier to this port. Whenever a faulty channel is detected and a changeover takes place, the input source of the standby unit shall be directed to the source of the affected channel.

10 FAULT CONTACT PORT

If a changeover takes place or a fault is detected, this shall provide a dry contact and be connected to external devices for monitoring purpose.

11 POWER INPUT SOURCE

This equipment operates under 24V DC. Please use recommended power supply - Amperes PS9400 or regulated power adaptor. Please observe polarity when connecting.

12 AMPLIFIER OUTPUT TERMINALS

Connect outputs from amplifiers to the "Input" and the "Output" terminal shall then be connected to speaker zone selectors.

13 STANDBY AMPLIFIER OUTPUT TERMINALS

This port is connected to the output from standby amplifier.

14 CHANNEL / AMPLIFIER DETECTION SWITCH

If any of the channel is not used, (less than 6 duty amplifiers), the corresponding channel switch should be turned off to avoid false detection.

15 CASCADE LINK

Two or more of AX3700 can be used when only a standby amplifier is available to serve more than 6 duty units. Use this link in criss cross connection. Please refer to the section "Cascading more than one unit".

16 RS485 PORT *

This is for external monitoring purpose via RS485 protocol.

Note :

This feature is for future upgrade and shall be available soon.

GENERAL SCHEMATIC 1 : SINGLE SOURCE SETUP

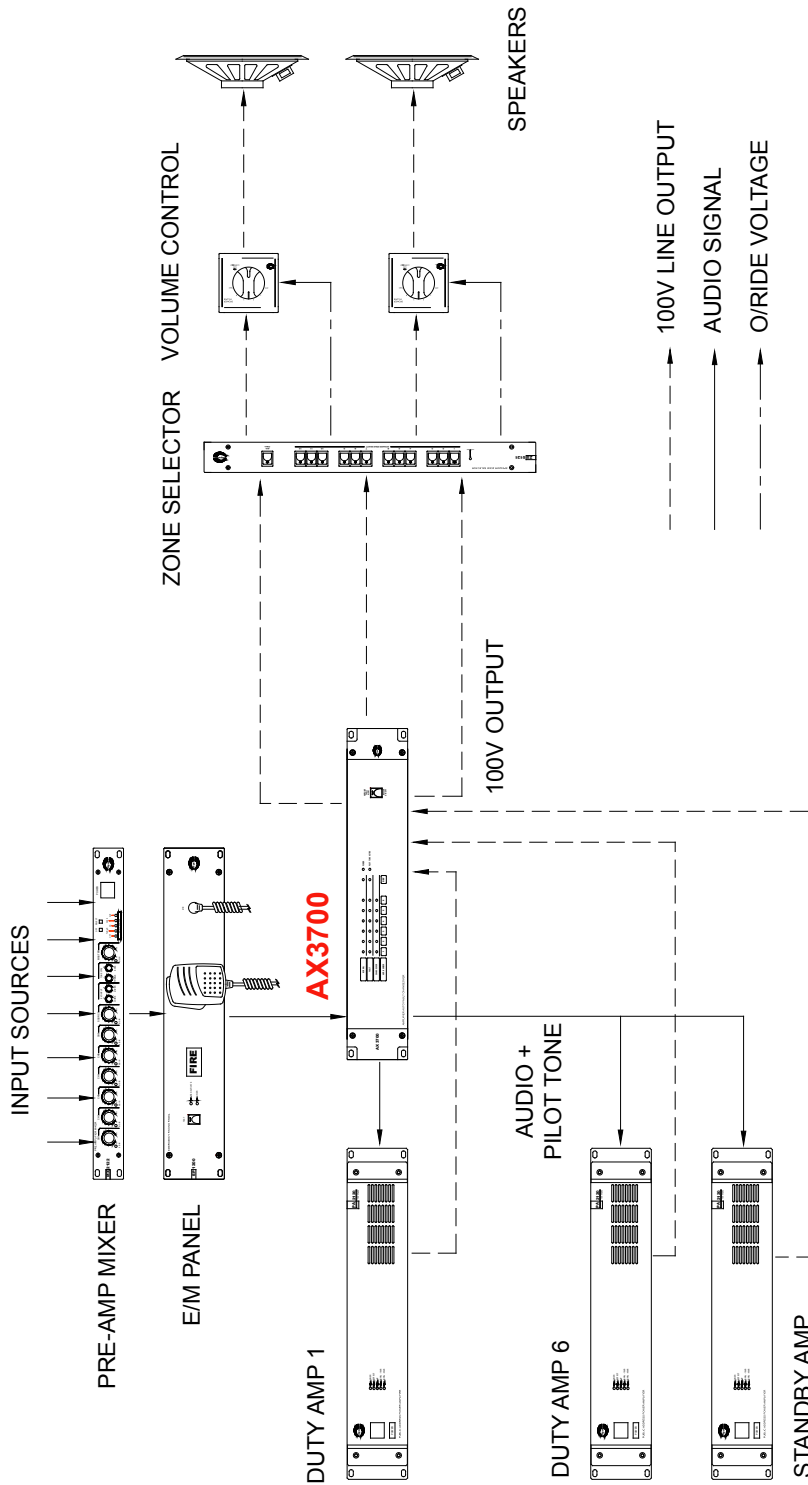

The above schematic is typical for single audio source application.

For uninterrupted paging setup, (2 audio source with separate amplifiers for paging and BGM, connections shall be typical to Matrix paging installations.

Please cascade more than one AX3700 when only a single standby power amplifiers is available to serve more than 6 duty power packs.

GENERAL SCHEMATIC 2 : MULTIPLE SOURCE SETUP

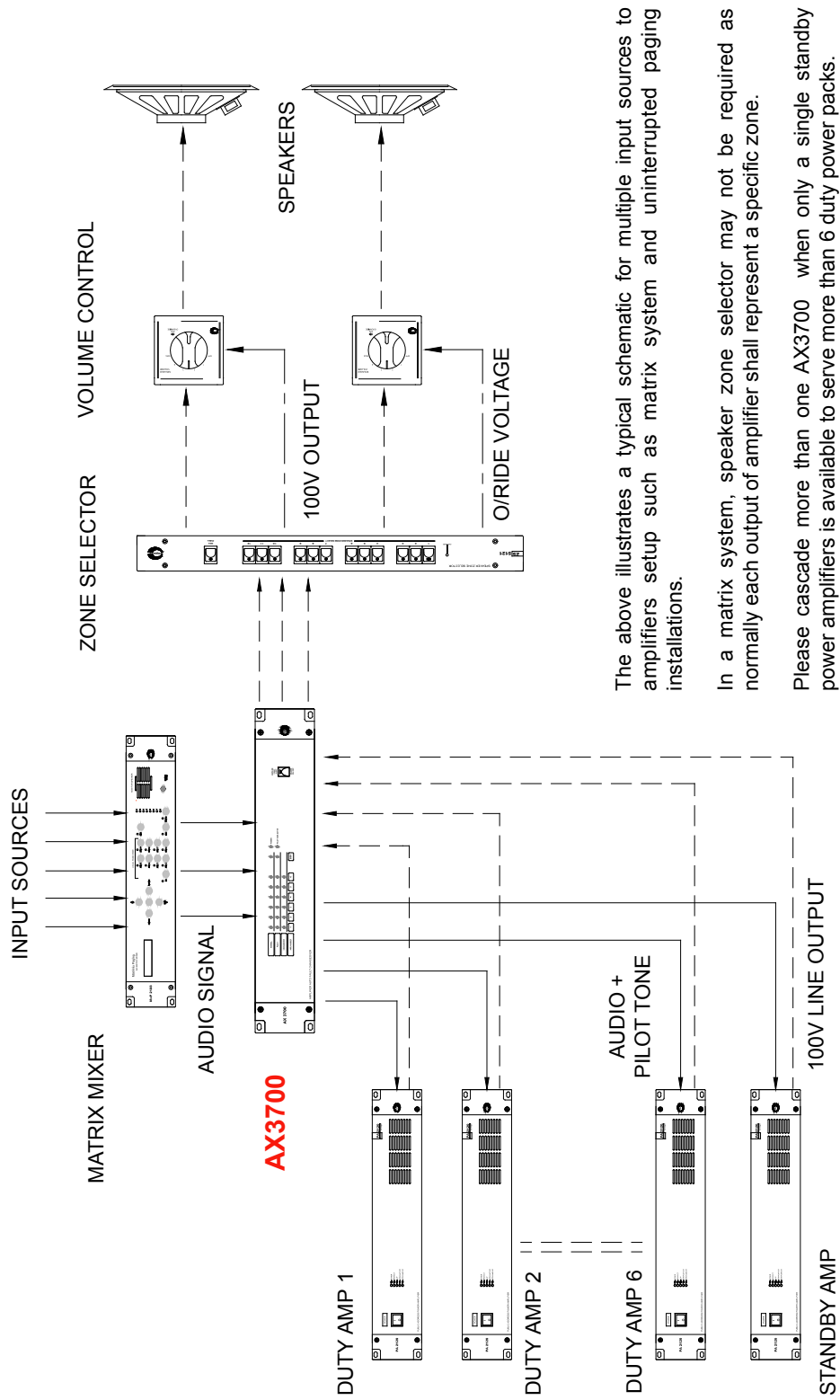

The above illustrates a typical schematic for multiple input sources to amplifiers setup such as matrix system and uninterrupted paging installations.

In a matrix system, speaker zone selector may not be required as normally each output of amplifier shall represent a specific zone.

Please cascade more than one AX3700 when only a single standby power amplifiers is available to serve more than 6 duty power packs.

CONNECTING THE UNIT - AUDIO INPUTS / OUTPUTS

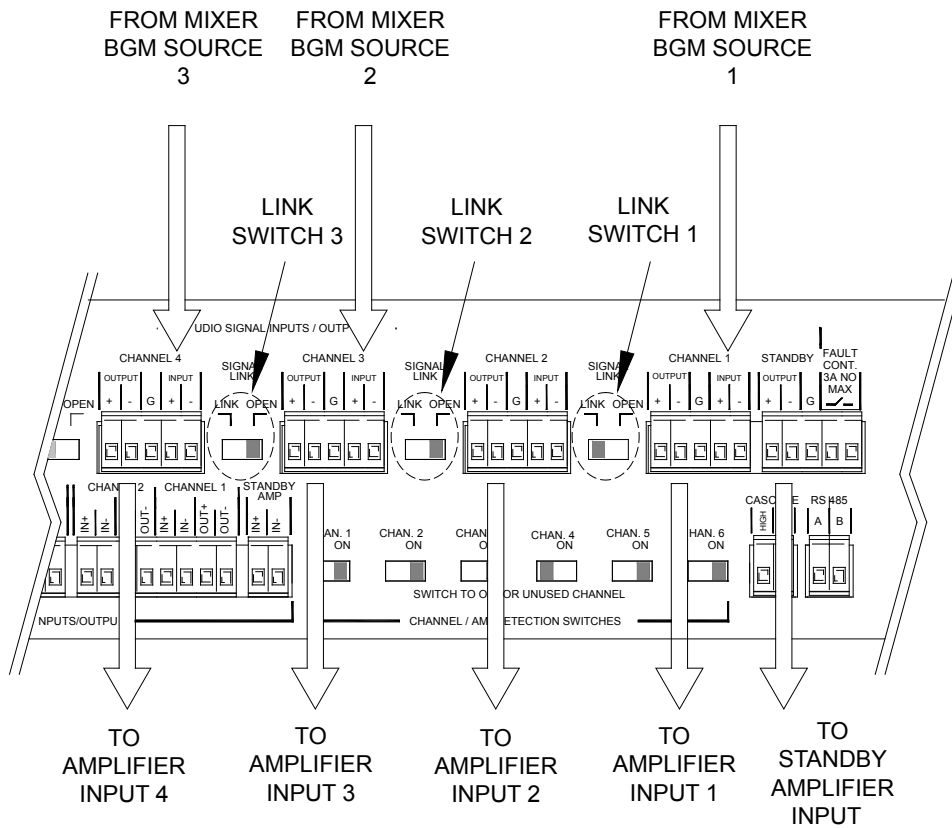

The above shall be for a setup of :

Amplifier 1 and 2 with same input source ; thus only input port of channel 1 is connected.
The Link Switch 1 is switched to link position.

Amplifier 3 and 4 shall have separate BGM source and their outputs shall be connected to the respective amplifier inputs.
Link Switches 2 and 3 shall be at OPEN position.

IF ONLY A SOURCE IS TO BE CONNECTED TO ALL AMPLIFIERS :

In the case that a single source is used for the whole installation, connect only to channel 1 and set all the link switches to LINK position.

NOTE :

Input and Output signal from AX3700 shall have unity gain. Therefore a single source shall be limited to max 6 output channels. If a source were to be connected to more than 6 amplifiers, it is recommended that a distribution amplifier is used before connecting it to the AX3700 input port.

Having a source connected directly to more than 6 amplifiers may cause impedance drop, probably causing distorted sound quality as well as signal drop.

CONNECTING THE UNIT - AMPLIFIER INPUTS - OUTPUTS

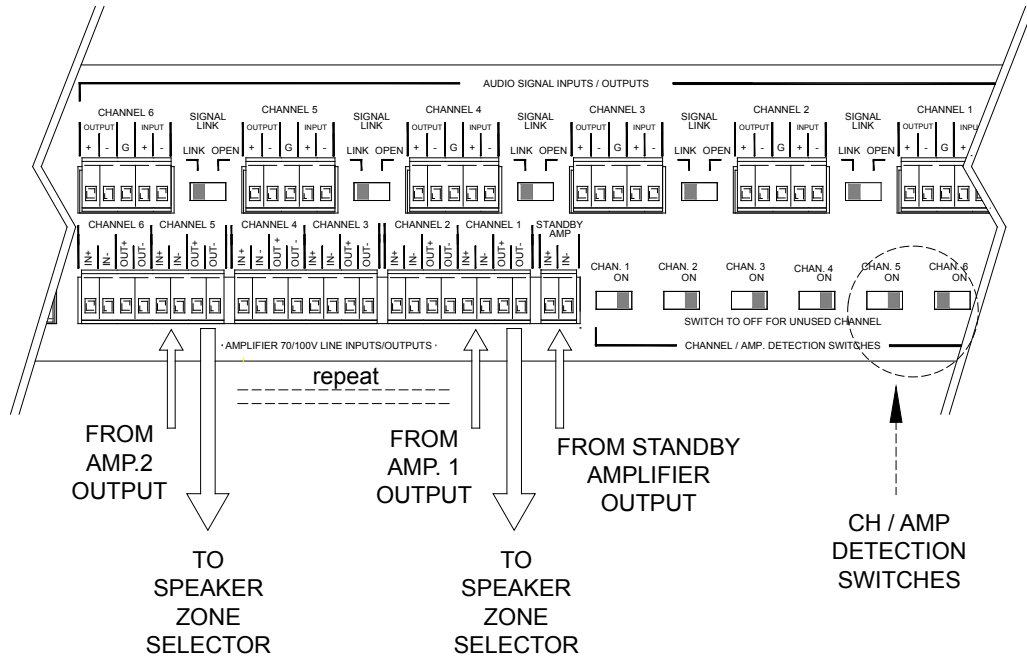

When connecting output of amplifiers to the AX3700, polarity must be observed.

Each output of the amplifier must be connected to the unit. A disconnected amplifier channel shall be regarded as a faulty channel and a changeover shall take place.

FOR UNUSED CHANNELS

Unused channel should be switched to OFF position at the CH/AMP DETECTION SWITCH. As for the above example, switch 6 for unused Amp input / output channel has been turned to OFF position.

CASCADING AX3700

When there is only one standby amplifier to serve more than 6 duty units, more than one AX3700 shall be used to serve the purpose.

All other settings as shown earlier shall apply.

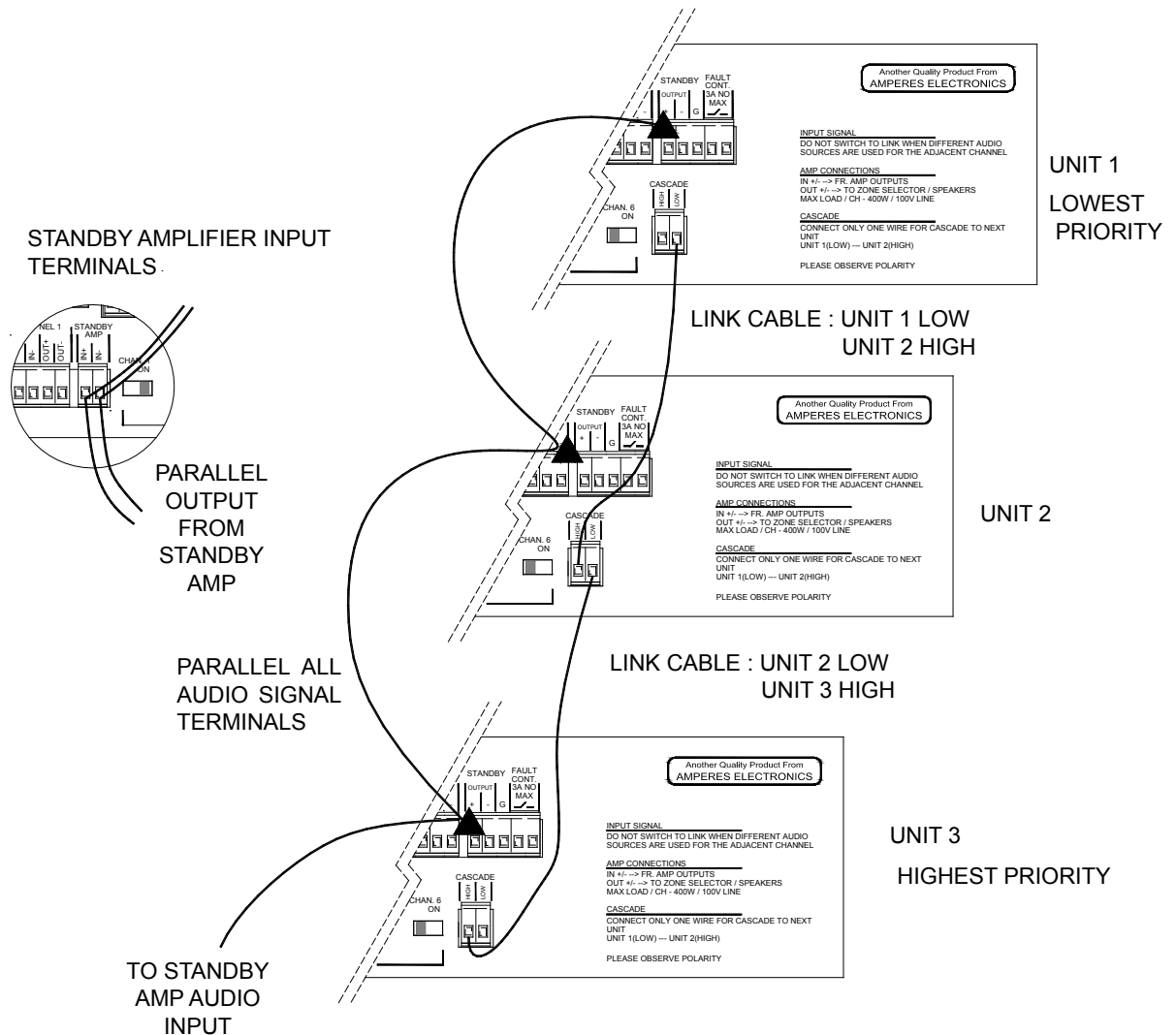

Use only one link from top to bottom as shown above.

Unit 3 shall have highest priority than 2, so as 2 than 1. Example. When there are two failures detected at unit 2 and 3, the channel at unit 3 shall be given preference than others. Thereby, arrange amplifiers that are critical in operation at lower unit.

If it is required to force the lower priority unit into takeover mode, please switch the CH/AMP DETECTION SWITCH at the related higher unit to OFF position.

FAULT DETECTIONS

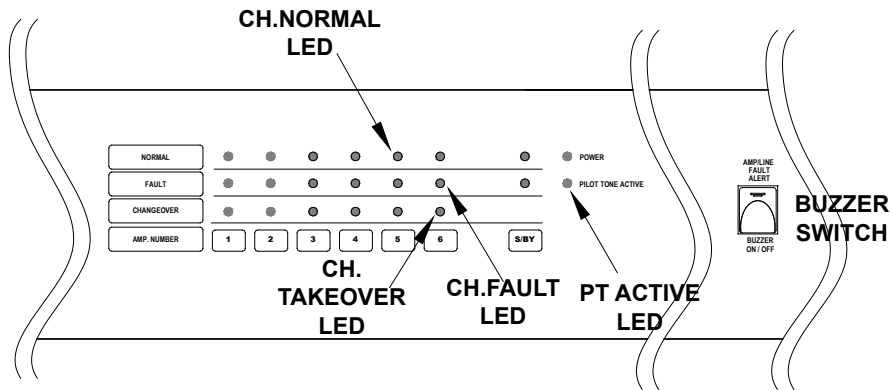

HOW IT WORKS

Although in principle most auto fault changeover works similarly in detecting faulty amplifiers, you may find some difference in how AX3700 operates. AX3700 sends out Pilot Tone of 20 KHz at intervals and shift from channel to channel. This reduces strain at the amplifiers where continuous loading is avoided. Though some slight delay may occur during the detection period, this shall be beneficial in the long run. The maximum fault detection window shall be around 25 seconds, which is acceptable in most cases.

Whenever Pilot Tone is active, PT ACTIVE LED shall lit, indicating that the unit is sending out 20KHz signals to individual channels

EFFECTIVE DETECTION LEVEL

AX3700 checks the returning PT signal from the output of amplifiers. A minimum 50V line rms is required for detection. Failing in detecting the returning signal shall render the channel faulty. Thereby it is recommended that the output of the amplifiers be set to 3/4 turn. AX3700 works even without the presence of audio signal.

INDICATIONS

Every faulty channel shall be indicated by CH FAULT LED. Unused channel which is not switched off shall also be regarded as faulty channel. Thereby when there is any unused channel, switch it to OFF to prevent false alarm.

Only a single takeover is allowed to prevent overloading of standby unit. Preference shall be given to unit with higher number for takeover. ie. When channel 2 and 6 is faulty, channel 6 shall be allowed for takeover. For cascading mode, please refer to section " Cascading AX3700 ".

Channel being takeover shall be indicated by CH.TAKEOVER LED. In the same time, buzzer shall be activated and this can be silenced by the BUZZER SWITCH.

A closed contact shall also be established, with the port provided at the rear of the panel. This can be linked to external sounder or mimic panel for indication.

RS485 port shall be available in future for activity monitoring.

TESTING THE INSTALLATIONS

POWER UP

With all cabling for input outgoing audio source, amplifier input and output channels connected, switch on the power to the unit. Please use regulated 24V DC with min 0.5A rating. Unregulated power supply may cause fault to the unit.

Once the power is on, all channels shall be at faulty position, and PT shall be sent to every individual channel. It shall take approximately 30 seconds for the system to normalise. Remember all amplifiers shall be switched on too.

TEST INDIVIDUAL WORKING FUNCTION

TEST PARAMETER

Switch off the power of the amplifier at Channel 1.

OBSERVATIONS

Normal LED at ch.1 shall off, Fault LED shall lit and followed by the takeover LED. Buzzer shall be activated. This action shall take a maximum time of 25 seconds.

Switch on the power of the amplifier 1.

The channel shall return to normal mode with Normal LED on, Fault and Takeover LEDs OFF as well as buzzer being silenced.

Repeat the above steps for Channel 2 to 6

TEST PRIORITY WORKING FUNCTION

TEST PARAMETER

Switch off the power of the amplifier at Channel 1.

OBSERVATIONS

Normal LED at ch.1 shall off, Fault LED shall lit and followed by the takeover LED. Buzzer shall be activated. This action shall take a maximum time of 25 seconds.

Switch off the power of the amplifier at Channel 2.

At Ch.1, Fault LED shall remain lit while Takeover LED shall be off.
At Ch.2, Normal LED off, Fault LED on and Takeover LED shall lit.

With amps at Ch1 and 2 still off, switch off the amp at Ch3.

At Ch.1,2, Fault LED shall remain lit while Takeover LED shall be off.
At Ch.3, Normal LED off, Fault LED on and Takeover LED shall lit.

Repeat the above steps with Ch4 switched off while the previous ones still at OFF position. You shall observe the same pattern at the indicators in sequence.

After channel 6, switch on the power amp in sequence from Ch6 to 1 and the observations shall be as opposite to the earlier procedures.

TECHNICAL SPECIFICATIONS

Operating voltage	24V DC ; 1A
Power consumption	7.2 W
Input signal	6 Ch balanced line signal
Input impedance	10 K Ohm
Audio output gain	Unity
Pilot tone interval	10 seconds / channel
Pilot tone frequency	20 KHz (+/- 5%)
Detection line	70 / 100 V line
Detection level	50 V rms min
Failure detection time	10 - 25 seconds
Failure recovery time	20 seconds max
Zone load rating	400W / 100V line
Status indication LED	Normal ; Fault ; Changeover
Changeover alert	Buzzer with switch
Changeover section	Input and output simultaneously
Dimensions (WxhxD)	482 x 88 x 150 mm
Weight	3 kg

SUMMARY OF FEATURES

Cater for 6 duty and 1 standby and expandable to allow a standby pack to serve larger quantity of duty amplifiers

Built in Pilot Tone generator which transmit at interval and senses at sequence to protect the power amplifiers

Overloading protection by allowing only a single take over

Prioritised changeover which higher numbered amplifier shall be preferred for take over in the event more than two units are down

Shorter fault detection time from 10 to 25 seconds

Changeover at input and output section simultaneously ; thus suitable for matrix system installations or uninterrupted paging setup.

Input link switch ; making connection of sources easier than hardwired loopings which would make interconnections look less messy.

Channel isolation switch for unused or unmonitored channels

Individual channel status indicators ; normal, fault and changeover

WARRANTY CONDITIONS

Only Amperes Electronics Service Centres are allowed to make warranty repairs : a list of Amperes Electronics Service Centres may be asked for by the purchaser or send directly to Amperes Electronics Sdn Bhd at 70 Jalan Industri PBP 3, Tmn Perindustrian Pusat Bandar Puchong, 47100, Puchong, Selangor, Malaysia or its authorized master distributor, Amperes Global Marketing. This warranty is not valid if repairs are performed by unauthorized personnel or service centres.

This warranty covers only repairs and replacement of defective parts ; cost and risks of transportation as well as removal and installation of the product from the main system are for the account of the purchaser. This warranty shall not extend to the replacement of the unit.

This warranty does not cover damages caused by misuse, neglect, accident of the product as well as using the product with power supply voltage other than shown on the product, or any other power supply source / adaptor not recommended by the manufacturer.

This warranty does not cover damages caused by fire, earthquakes, floods, lightning and every cause not directly related to the unit.

This warranty does not include any indemnity in favor of the purchaser or the dealer for the period out of use of the unit; moreover the warranty does not cover any damages which may be caused to people and things when using the product.

This warranty certificate is valid only for the described product, and is not valid if modifications are made on this certificate or on the identification label applied on the product.

This warranty covers all the material and manufacturing defects and is valid for a period of 12 months from the date of purchase or for a longer period in countries where this is stated by a national law. In this case, the extension is valid only in the country where the product is purchased.

Amperes Electronics Sdn Bhd is not obliged to modify previously manufactured products under warranty if the design changes or improvements are made.

DISCLAIMER

Information contained in this manual is subject to change without prior notice and does not represent a commitment on the part of the vendor. AMPERES ELECTRONICS SDN BHD shall not be liable for any loss or damages whatsoever arising from the use of information or any error contained in this manual.

It is recommended that all services and repairs on this product be carried out by AMPERES ELECTRONICS SDN BHD or its authorized service agents.

AMPERES series must only be used for the purpose they were intended by the manufacturer and in conjunction with this operating manual.

AMPERES ELECTRONICS SDN BHD cannot accept any liability whatsoever for any loss or damages caused by service, maintenance or repair by unauthorized personnel, or by use other than that intended by the manufacturer.