

# MX 2222

## PRE AMPLIFIER MIXER

### INSTRUCTION MANUAL

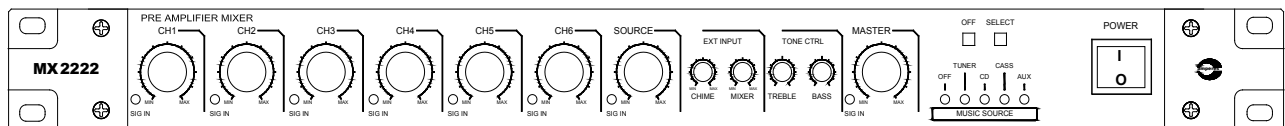

*Thank you for selecting and trusting another product from Amperes Electronics.*

MX2222 is a product born out from years of experience and untiring research in BGM / Paging applications. It succeeded its predecessor, MX2122 with few additions to its features while improving some specifications. MX2222 may appear indifferent from other pre-amplifier mixer, but do not be mistaken with its appearance. Its small compact size offers unbeatable features for application in general paging system or BGM broadcasting, conference room audio mixing, lecture theater sound reinforcement system and many other applications to your imaginations.

MX2222 offers a great product with reliability, accuracy and quality which every unit is tested to stringent testing method with state of the art testing tool. Make MX2222 a part of your delicate system and experience what Amperes has to offer from its range of products.



**amperes electronics**  
www.ampereselectronics.com

## IMPORTANT SAFETY INSTRUCTIONS

The lightning flash symbol with arrowhead within an equilateral triangle is intended to alert the user to the presence of uninsulated "dangerous voltage" within the product's enclosure, that may be sufficient magnitude to be a risk of electric shock to person.

The exclamation mark within an equilateral triangle is intended to alert the user to the presence of important operating and maintenance (servicing) instructions in the literature accompanying the appliance.

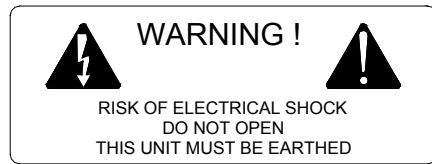

**WARNING** - When using electric products, basic precautions should always be followed including the followings :

1. Read all the SAFE INSTRUCTIONS before using the product.
2. This product must be earthed. If it should malfunction or breakdown, grounding provides a path of least resistance for electric current to reduce risk of electric shock.

This product is equipped with a cord having an equipment grounding conductor and a grounding plug.

The plug must be plugged into an appropriate outlet that is properly installed and earthed in accordance with all local codes and ordinance.

**DANGER** - Improper connection of the equipment-grounding connector can result in a risk of electric shock. Check with a qualified electrician or servicemen if you are in doubt as to whether the product is properly grounded. Do not modify the plug provided with the product, If it will not fit the outlet, have a proper outlet installed by a qualified electrician.

3. To reduce the risk of injury, close supervision is necessary when the product is used near children.
4. Do not use this product near water, for example, near a bathtub, washbowl, kitchen sink, in a wet basement or near a swimming pool or the like.
5. This product should be located so that its location or position does not interfere with its proper ventilation.
6. This product should be located away from heat sources such as radiators, heat registers or other products that produce heat.
7. This product should be connected to a power supply only of the type described on the operating instructions or as marked on the product.
8. This product may be equipped with a polarized line plug (one blade wider than the other). This is a safety feature. If you are unable to insert the plug into the outlet, contact an electrician to replace your obsolete outlet. Do not defeat the safety purpose of the plug.
9. The power supply cord of the product should be unplugged from the outlet when left unused for a long period of time. When unplugging the power supply cord, do not pull on the cord, but grasp it by the plug.
10. Care should be taken so that object do not fall and liquid are not spilled into the enclosure through openings.
11. The product should be serviced by a qualified service personnel when :
  - a. The power supply cord or the plug has been damaged or,
  - b. Objects has fallen, or liquid has been spilled into the product, or
  - c. The product has been exposed to rain, or
  - d. The product does not appear to operate normally or exhibits a marked change in performance, or
  - e. The product has been dropped or the enclosure damaged.
12. Do not attempt to service the product beyond that described in the user-maintenance instructions. All other serving should be referred to qualified service personnel.
13. **WARNING** - do not place objects on the products' power cord or place it in a position where alone could trip over, walk on or roll anything over it. Do not allow the product to rest on or to be installed over power cords of any type. Improper installations of this type create the possibility of fire hazard and / or personal injury.

Although MX2222 may sound familiar to you like other mixer, we recommend a brief read out of this manual to avoid any error in installation. A few minutes of reading is all that it takes to capture the full features this mixer has to offer. We believe the instructions laid shall enable you to install it correctly, professionally and commission them to the full satisfaction of your clients.

Kindly keep this manual for any future reference.

## **PARTS IDENTIFICATIONS ( front view )**

### **1. MIC INPUT VOLUME KNOBS**

The rotary knobs for microphone inputs 1 to 6 are for adjustment of input signal levels before the main mix output. In setup, adjust this gain to the optimum level according the required output level. Different channel may have different input source (ie. condenser mic or dynamic mic, etc ), thereby the level of different channels may be set differently.

Adjustment high gain may distort the original signal but too low may cause insufficient signal to the mixer output. Thereby trim each channel individually by fixing the main output to a certain level ( 75% ) while turning off other channels. Repeat this step and mark the level at each knob to avoid constant sound setup.

Mic channel 1 and 2 ( and external mixer and chime inputs ) would have priority over other mic input channels. This muting can be disable by adjusting the mute level control at the back of the unit. By disabling this function, the mixer can be applied to wider usage such as hall of prayer, lecture theaters, etc.

### **2. SIGNAL LED**

The presence of input signal is indicated at this LED. The strength of input signal shall determine the brightness of the LED output.

### **3. BGM SOURCE LEVEL KNOB**

This knob is used to adjust the level of music source signal which has been selected from the source selector. Although different type of music players may have different output level, the selected source shall have a constant output thanks to its inputs balancing circuitry. Therefore a one time BGM source setup shall be enough whenever BGM source switching is made. Adjusting the volume shall also affect the level of BGM output terminal.

Setup for the required output level of BGM source shall be similar to setup for microphone inputs and we always recommend a marking at the knob scale whenever the optimum level is reached.

### **4. CHIME INPUT LEVEL KNOB**

External chime / tone or siren generator may be connected to the mixer which would have priority over other channels. Thereby the presence of chime signal shall override or mute other inputs except external mixer, mic input 1 and 2. The level of the chime signal can be adjusted via this knob but the priority feature cannot be bypassed.

### **5. EXTERNAL MIXER LEVEL KNOB**

External mixers are used when more input channels are required, when linking separate PA systems in different buildings. Adjust the appropriate level using this knob by following above mentioned method of setup.

External mixer input together with Mic 1 and 2, and chime inputs have priority over other channels. This function can be disabled by adjusting priority mute level knob. See item 19.

# PARTS IDENTIFICATIONS

FRONT VIEW

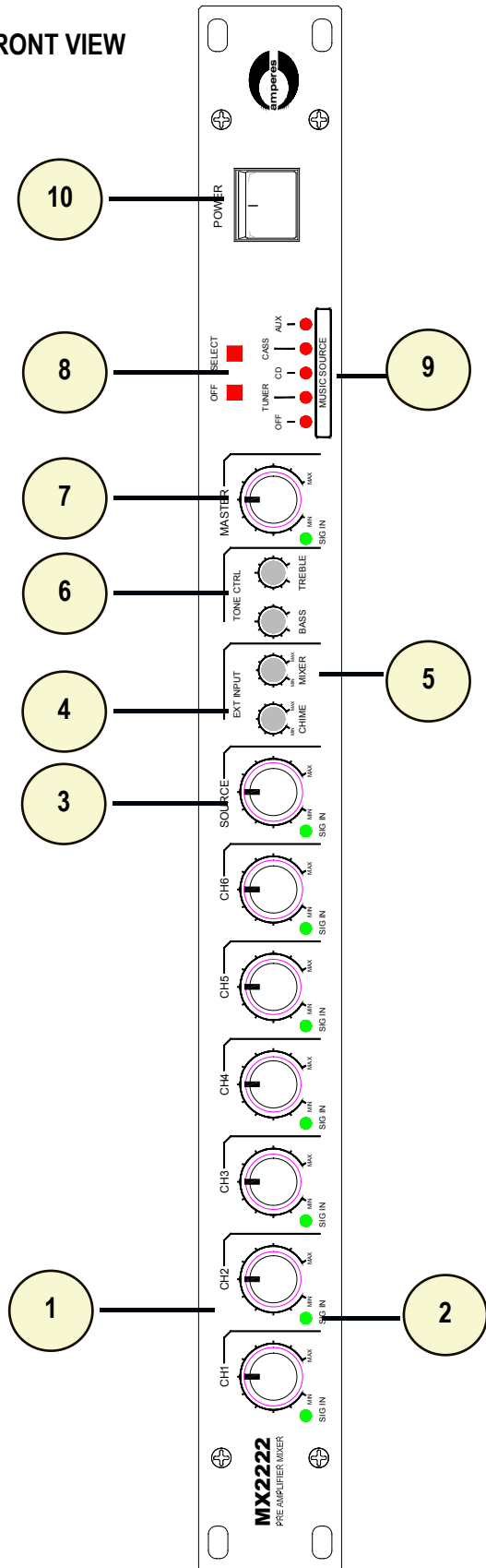

REAR VIEW

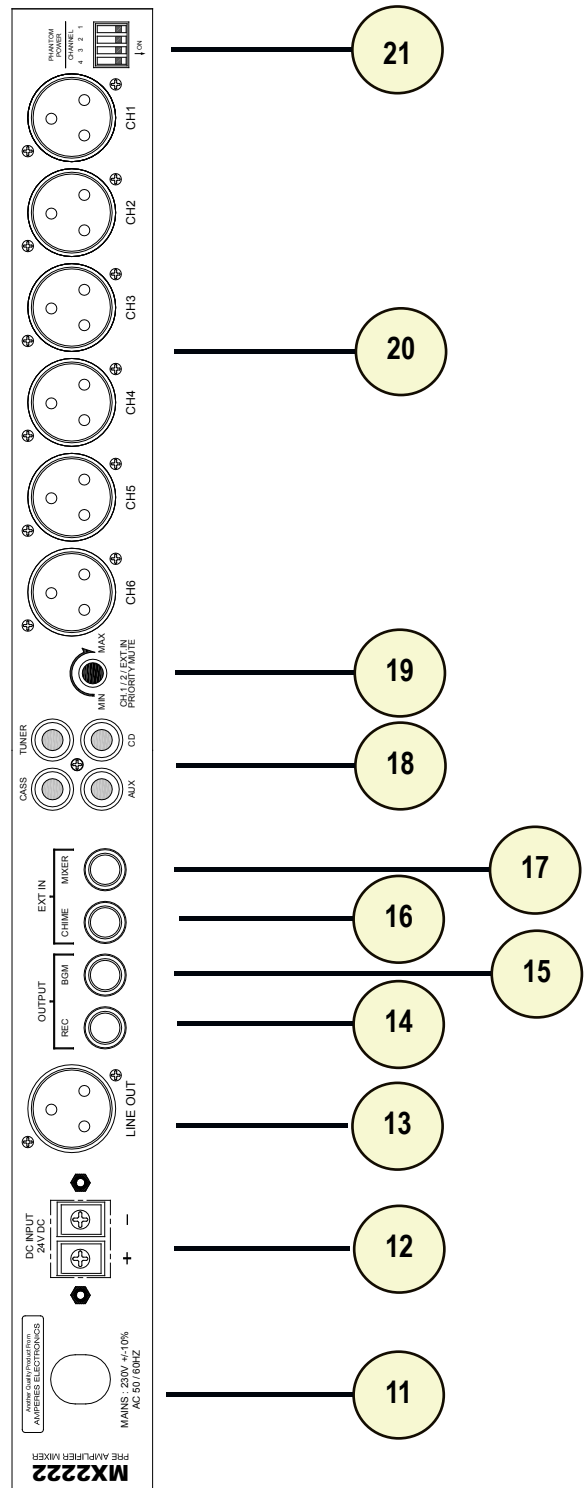

## **PARTS IDENTIFICATIONS ( front view.....con't )**

### **6. BASS AND TREBLE KNOBS**

The bass and treble of mix signal output can be adjusted to the desired hearing comfort via these level knobs. Appropriate adjustment of these signal can reduce sound feedback to a certain level but not complete elimination.

### **7. MAIN OUTPUT LEVEL KNOB**

Overall output level is adjusted using this knob. To avoid over amplification, it is recommended this level be set to approximately 75%.

It is advisable that the gain be set to minimum when powering the system as well as shutting down as this can eliminate sudden signal burst to your system.

### **8. SOURCE SELECTION BUTTON**

BGM source or music players such as cassette player, CD, tuner or other Aux can be selected using these buttons. Once selected, the input source shall be directed into two paths, ie to the main mixing circuit and the other as direct output.

Path to the mixing circuit would mix with other channels, with its level adjustable and finally to the mixer output. The direct output path is independent from any input level control and is connected to external amplifiers, etc via phone jack. This is suitable for application in dual channel PA systems which broadcast music source and paging uninterrupted to various zones.

In connecting BGM source, each input channel is to be connected to the right player and should not be interchanged.

### **9. BGM SOURCE LED**

The selected BGM source shall be indicated by these LEDs.

### **10. MAIN POWER SWITCH**

AC input to the mixer is switched at this part. However if the unit is also connected to 24V DC back up supply, switching off this switch would still render the unit active. ie. the switch is independent from 24V DC back up source.

## **PARTS IDENTIFICATIONS ( rear view )**

### **11. AC POWER CORD**

The unit has been preset to operate under 230V / 240V ac mains supply unless otherwise specified. The ac fuse located at the plug top shall only be replaced with a rating of 5A max.

## **PARTS IDENTIFICATIONS ( rear view )**

### **12. DC INPUT SUPPLY**

MX2222 can also operate using 24V DC supply. When both AC and DC source is connected to the mixer, it shall operate using the ac main whereas the DC supply shall only be consumed whenever the former failed.

We recommend that only a regulated 24V DC supply is used when the ac mains is disconnected. This back up terminal power source can be obtained either from back up battery or UPS unit.

### **13. MIXER MAIN OUTPUT**

This XLR connector delivers the mixed signal output from all the input sources, ie. BGM source, external links as well as microphone inputs. The output signal is electronically balanced with 600 Ohm impedance and 1.25V max.

LEARN more about BALANCE / UNBALANCE SIGNAL in the following chapter.

### **14. REC OUT ( PHONE JACK )**

This unbalanced line signal is to be connected to recording media such as cassette tape recorder.

### **15. BGM OUT ( PHONE JACK )**

Selected BGM source from the front panel source selector button shall has a direct output via this jack. This can be utilized for dual channel BGM / Paging broadcast system. Also refer to Paragraph 8.

### **16. CHIME INPUT JACK**

External chime / tone generator is connected to this jack and shall automatically mute signals from other channels except External Mixer and Microphone Ch 1 and 2. Priority level of this input is last after Mixer and Mic 1 and 2.

### **17. MIXER INPUT JACK**

External mixer shall be connected to this input and in the presence of the signal, it shall mute other sources. Priority level is the highest for this channel.

### **18. BGM SOURCE INPUTS**

BGM source such as Cassette Player, CD, Tuner and Aux are connected via RCA jack. Please do not interchange the assigned inputs as different players shall have different output levels. Wrong assignment shall cause undesired output due to signal leakage.

### **19. PRIORITY MUTE LEVEL SETTING**

The muting circuitry activates in the presence of signals that are presence in Ext Chime or Ext Mixer Input or Mic 1 and 2. This knob adjustment determines the mixing level of mic or line input signals with the signals of priority channels. Adjusting it to minimum shall cut off all other inputs when signal is presence in priority channels, Whereas setting it to max shall allow free mix of all signals including priority inputs.

Some application shall not require this feature, such as in the hall of prayer, thereby to bypass the circuitry, adjust the level to the maximum.

## 20. MICROPHONE INPUT JACKS

Microphones inputs 1 to 6 are connected to the mixer using XLR connectors with balanced signal. Mic input channel 1 and 2 shares the priority level. If both signals are present, they will be mixed while muting other normal channels.

## 21. PHANTOM POWER DIP SWITCH

Phantom power are available for microphone input 1 to 4 with output level of 12V DC. This feature shall be useful when condenser microphones are to be used, such as tie clip or gooseneck microphones.

The feature can be switched off if not required. It is recommended that the power is switched off when using mics other than condenser or whenever a condenser mic with external or integrated phantom power is available.

## BALANCED AND UNBALANCED .... the difference and effects

Some installations produces audio output which is far undesired from others, mainly due to the wrong method of cabling or terminations. This is apparently true for installations which have cables carrying signal of sources distance apart from the main rack or interconnecting separate racks or perhaps due to improper grounding understanding. To understand why noise appears in the system, we have to understand the basic theory of signal transmission, ie. Balanced and Unbalanced signal operation.

### Unbalanced Signal

Unbalanced system is found in most of home AV system which uses two conductors to carry the signal, one being the 'hot' and the other for 'ground'.

### Balanced Signal

2 twisted cable and a ground shielding conductors are used to carry signal in a balanced system. The two signal conductors transmit the identical input signals but are out of phase with each other and the ground shielding conductor carries no signal but would pick up noise along the way to the system. However due to the amplification circuitry, useful signal shall be amplified twice while the noise shall be eliminated.

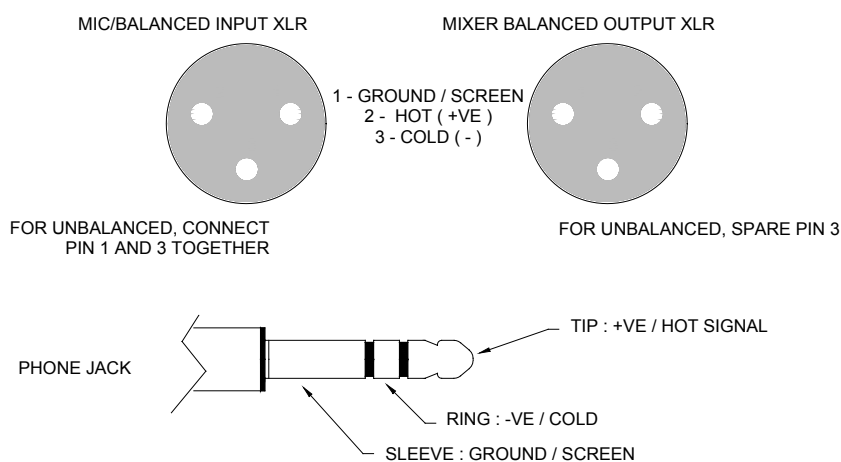

## The Significant Difference

In unbalanced system, only one conductor carries the useful signal while the other being the ground. Cables run in a distance may act as an antenna picking up radiations from ac sources, or from dimmers as well as other noises. Since there is no out of phase signals in the cabling, the noise signals shall superimpose with useful audio signal. As the signal level is rather small which could not diminish the effects of radiations, they would be amplified as one lot of signal, thereby hum, etc is heard together with audio signal. This could be disastrous if the cable is run in a longer distance which criss cross with other cabling like dimmer system, etc.

Noise may appear in a balance system but at a much lower magnitude as compared to unbalanced system. Microphones which generates amplitude in millivolts requires a better signal carrying method, ie. balance system. Signal produced are out of phase with each other and when reaching the op-amp, one conductor shall be amplifier positively while the other inverted. Noise which do not have polarity shall be canceled at the op-amp output. Thereby the useful signal is amplified twice while the noise is subdued.

The understanding of how this works can be easily illustrated in the diagram below.

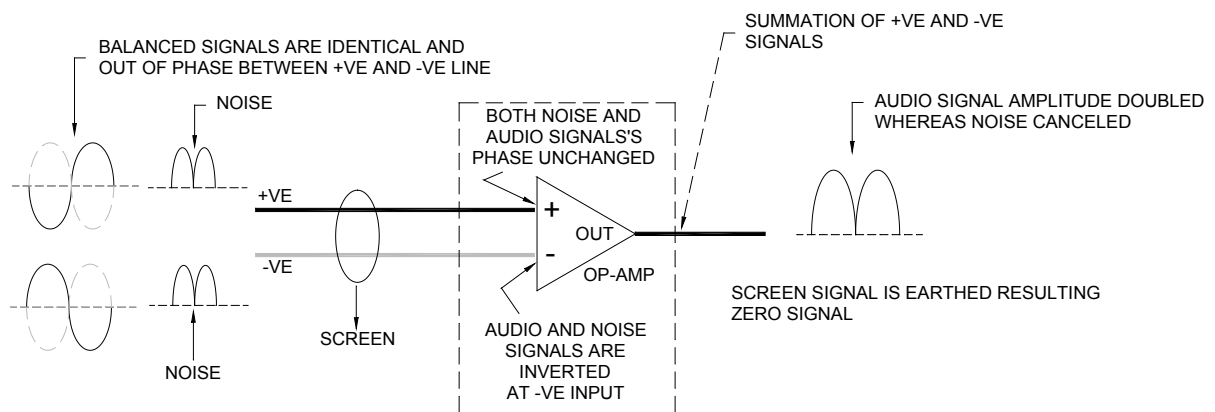

## The Proper Cabling - Ground Looping

It is important that the mains power is connected to your equipment with earth and the power system has a proper earthing. When hum exists, it is possibly due to poor grounding connection of your system. There should be only one ground point in the entire system.

Pin 1 of XLR at source equipment should be connected whereas at the destination, this pin is dismantled. This shall eliminate grounding loop due to connections of signal ground and power ground. A looped cable resembles an antenna picking up hum and other electromagnetic radiations. Although earthed equipment may cause mains hum, disconnecting signal screen is a preferred choice as it has higher resistance than earth ground.

# CONNECTING THE UNIT

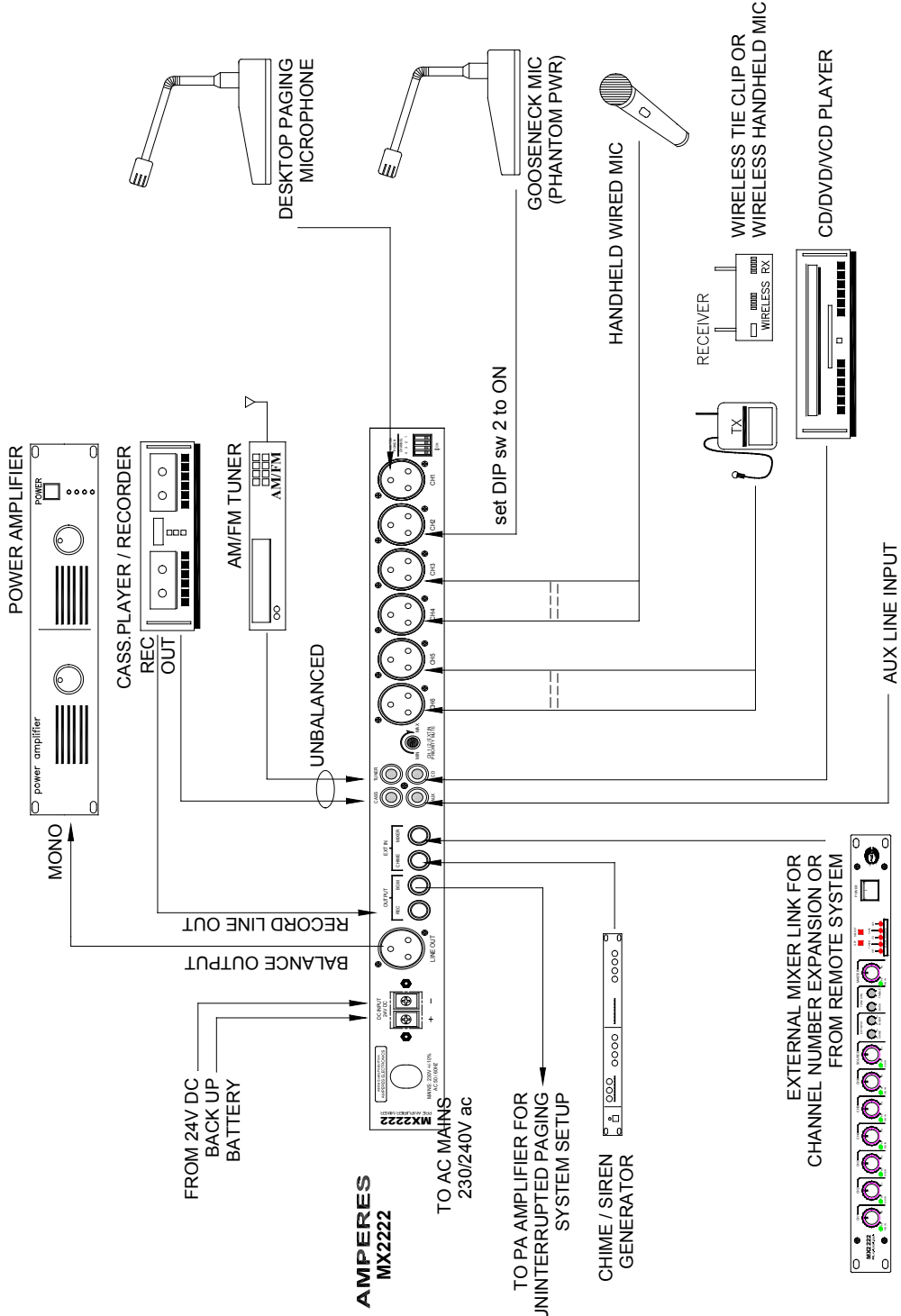

Above diagram shows typical equipments that can be connected to the mixer. Channel allocation for equipments shall not necessary follow the above illustration.

## APPLICATION EXAMPLE ... BGM / Paging System

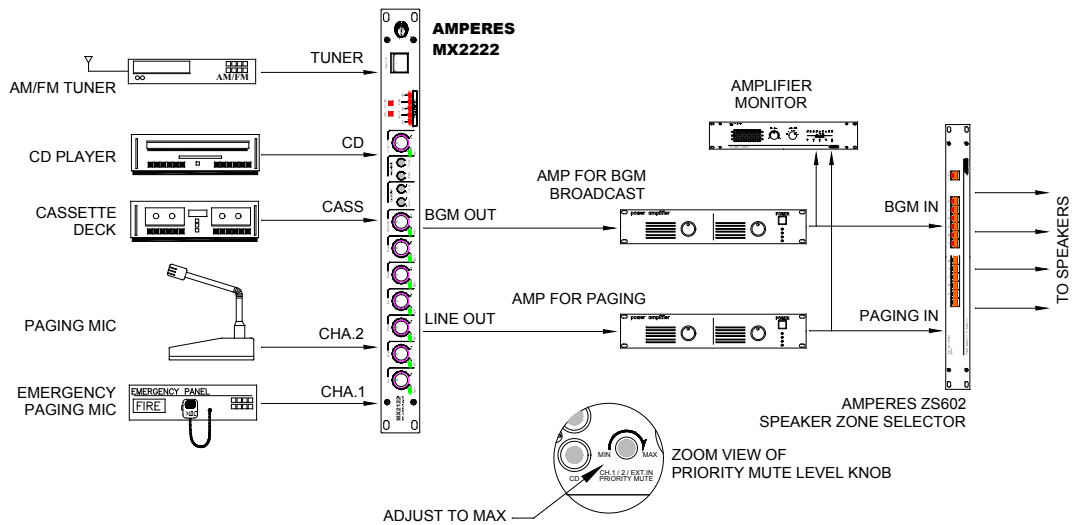

The above schematic illustrates a setup for a basic uninterrupted paging system.

Note that the priority mute level knob is adjusted to the maximum to allow the mute feature to be fully active. This level can be adjusted mid way or so if it is to allow a paging to be made with background music audible at lower volume.

Other equipments such as amplifier changeover, back up batteries, etc are not shown, which may be required according to the building design requirements.

## APPLICATION EXAMPLE ... Lecture Hall / Conference Room

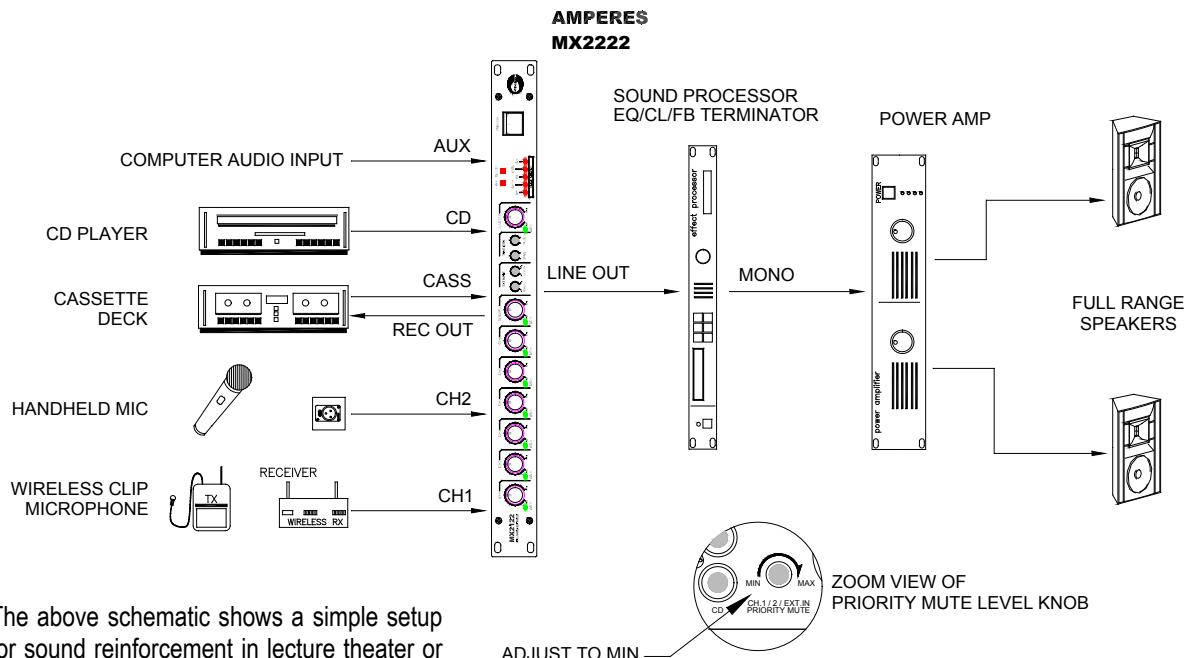

The above schematic shows a simple setup for sound reinforcement in lecture theater or conference room or hall of prayer.

Note that the priority mute level is set to minimum, thus allow free mix of signal from all channels.

## TECHNICAL SPECIFICATIONS

Operating Voltage	230 /240V ac or 24V DC (1 A)
Power Consumption	2.4W / 100 mA 24V DC
Input Channels	6 x Microphones 1 x External Mixer 1 x External Chime 4 x BGM Source
Phantom Power Channel	12V DC Channel 1 to 4, switchable via rear DIP switch
Max Input Level ( Mic )	0.775 mV (Gain unity, 1 KHz)
Input Impedance / Sensitivity	Microphones ( 600 Ohm Balanced ) : 0.775 mV Chime ( 10 K Ohm Unbalanced ) : 0.7 V Mixer ( 600 Ohm Balanced ) : 0.7 V BGM Source ( 47 K Ohm Unbalanced ) : 0.2 V
Output Connections	XLR for Mixed Output / Phone jack for BGM Output
Output Level	1.25 V 600 Ohm Balanced / +4 dB
Controls	Individual Mic Input Volume Chime and Mixer Input Volume Bass and Treble BGM direct output volume control Master Out
Tone Controls	Bass at 100 Hz (+/- 12 dB range) Treble at 10 KHz (+/- 12 dB range)
Frequency Response	30 - 19 kHz ; +0 / -5dB
Signal / Noise Ratio	> 60 dB ( +4 dBu, 20 KHz Bandwidth )
Dimensions	482 (W) x 44 (H) x 180 (D) mm
Weight	3.5 kg
Colour	Black

*The above specifications may change without prior notice subject to our product improvement policy*

## WARRANTY CONDITIONS

Only Amperes Electronics Service Centres are allowed to make warranty repairs : a list of Amperes Electronics Service Centres may be asked for by the purchaser or send directly to Amperes Electronics Sdn Bhd or its authorized master distributor, Amperes Global Marketing. This warranty is not valid if repairs are performed by unauthorized personnel or service centres.

This warranty covers only repairs and replacement of defective parts ; cost and risks of transportation as well as removal and installation of the product from the main system are for the account of the purchaser. This warranty shall not extend to the replacement of the unit.

This warranty does not cover damages caused by misuse, neglect, accident of the product as well as using the product with power supply voltage other than shown on the product, or any other power supply source / adaptor not recommended by the manufacturer.

This warranty does not cover damages caused by fire, earthquakes, floods. lightning and every cause not directly related to the unit.

This warranty does not include any indemnity in favor of the purchaser or the dealer for the period out of use of the unit; moreover the warranty does not cover any damages which may be caused to people and things when using the product.

This warranty certificate is valid only for the described product, and is not valid if modifications are made on this certificate or on the identification label applied on the product.

This warranty covers all the material and manufacturing defects and is valid for a period of 12 months from the date of purchase or for a longer period in countries where this is stated by a national law. In this case, the extension is valid only in the country where the product is purchased.

Amperes Electronics Sdn Bhd is not obliged to modify previously manufactured products under warranty if the design changes or improvements are made.

## DISCLAIMER

Information contained in this manual is subject to change without prior notice and does not represent a commitment on the part of the vendor. AMPERES ELECTRONICS SDN BHD shall not be liable for any loss or damages whatsoever arising from the use of information or any error contained in this manual.

It is recommended that all services and repairs on this product be carried out by AMPERES ELECTRONICS SDN BHD or its authorized service agents.

AMPERES series must only be used for the purpose they were intended by the manufacturer and in conjunction with this operating manual.

AMPERES ELECTRONICS SDN BHD cannot accept any liability whatsoever for any loss or damages caused by service, maintenance or repair by unauthorized personnel, or by use other than that intended by the manufacturer.



AMPERES ELECTRONICS SDN BHD  
E Mail : [amperes@streamyx.com](mailto:amperes@streamyx.com)  
MADE IN MALAYSIA  
Published : Sept 2006